



# Paddle-Ribbon Blender

Combination of outer paddle & inner ribbon



Combining the best of both worlds, American Process Systems® (APS) developed the combination outer paddle and inner ribbon agitator for applications involving fragile and heat sensitive products such as cereals, leafy spice mixes, and to prevent sugars from caramelizing.

- Gentler than a ribbon blender
- Faster than a paddle blender
- Greater range of batch sizes in relation to total capacity
- A better option for fragile products

## Double-Ribbon Blenders

The two ribbons of the traditional ribbon agitator create a counter-directional flow of materials, keeping the product in constant motion throughout the vessel. Goods are evenly distributed over the entire length of the mixing tank.

The outer ribbon creates pinch points between its edges and the tank wall, often resulting in damage to fragile products.

## Paddle Blenders

While being gentler, mixers with a paddle-style agitator require longer mixing cycles. Because the traditional paddle-style agitator is less efficient, it puts stricter limitations on volume capacity and batch size. Goods form a mound in the center of the mixing tank.

## The Combination Paddle-Ribbon Agitator

By combining an outer paddle arrangement with an inner ribbon, APS has developed a perfect solution for many applications.

The outer paddles in place of the ribbon minimize pinch points along the tank wall. Instead of mounding the product in the center of the vessel, the inner ribbon moves the product toward the ends much like it does in a conventional ribbon blender. The paddles gently scoop up the product and move it back toward the center discharge. Less frictional heat is introduced into the product than would be with a second ribbon.

Another benefit of the outer paddle/inner ribbon configuration is the greater range of batch sizes, particularly at the low end of the scale. While double-ribbon blenders are limited to no less than 40% of their batch capacity, the combination agitator allows for smaller batches much like those of a paddle blender. They may be as low as 10% of the rated batch capacity depending on the mix ingredients.

# Product Flow Diagrams

## Inner and outer ribbon

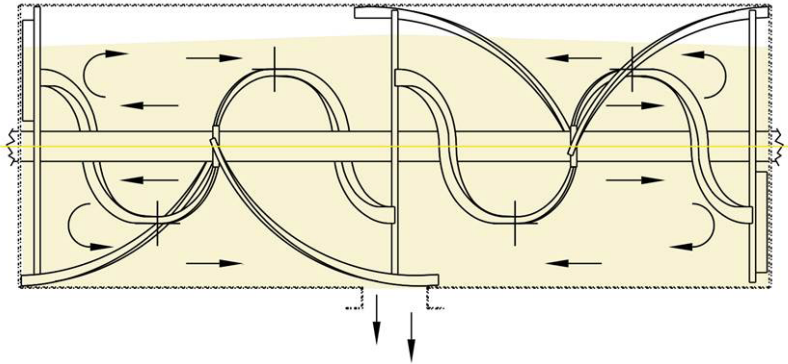

- Product will be leveled across the length of the blender
- The spiral of the ribbons will pull product in opposite directions
- More mechanical energy (shear) is transmitted to the product because of greater agitator surface
- Shorter mixing times required

## Paddles only

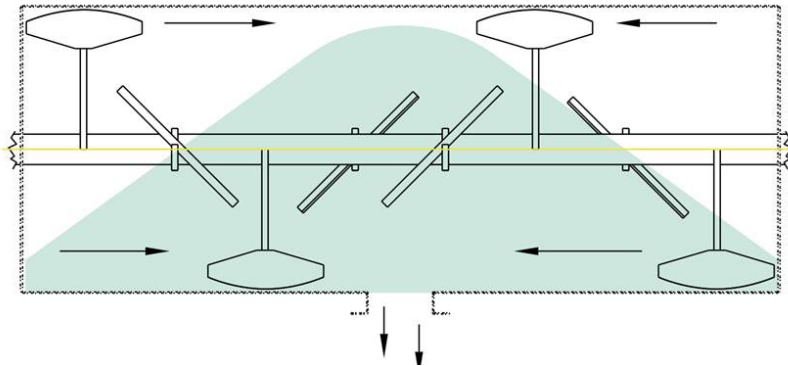

- Product will mound in the center of the blender
- Paddles lift product to the center of the blender
- Less mechanical energy is transmitted to the product because of smaller agitator surface (gentle lifting action)
- Requires longer mixing times
- Smaller working capacity

## Combination outer paddle and inner ribbon

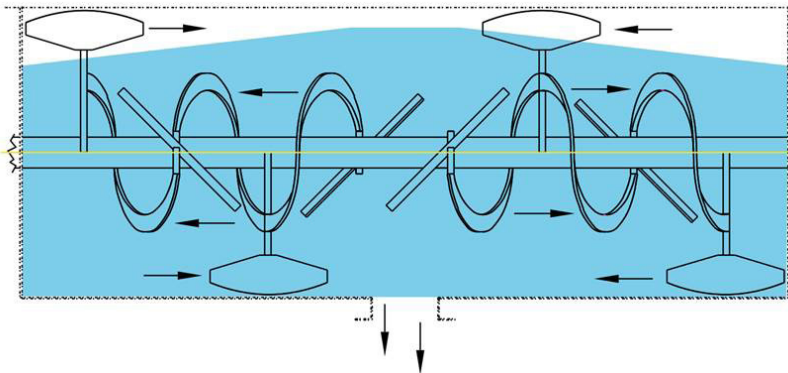

- Product will be more leveled across the length of the blender
- Outer paddles lift product to the center of the blender. Inner ribbon pulls product to both ends of the blender
- Less mechanical energy is transmitted to the product because of smaller agitator surface (gentle lifting action)
- Requires shorter mixing times than paddles only

**Eirich Machines**, part of worldwide Eirich Group, is an international supplier of machinery, systems, and services for material processing. With the two product lines EIRICH and American Process Systems® (APS), we offer the most comprehensive range of mixers, blenders, pelletizers, dryers, and grinding mills.

05/24 Printed in U.S.A. • Subject to changes

### Our APS product line includes:

- Fluidizing Paddle Blenders
- Ribbon Blenders
- Paddle-Ribbon Blenders
- Paddle Blenders
- Plow Blenders
- Dryers/Reactors



**Eirich Machines, Inc.**

4033 Ryan Road

Gurnee, IL 60031

847-336-2444

eirich@eirichusa.com

www.eirichusa.com