



OptimaBlend®

Fluidizing Paddle Blender

Sanitary blender for efficient but gentle blending of particles of various size, shape, and density.



**AMERICAN
PROCESS SYSTEMS**
EIRICH GROUP

The Pioneer in Material Processing®

OptimaBlend®

Fluidizing Paddle Blender

Since 2003



OptimaBlend® Mixing Technology - Designed and engineered by APS in 2003

American Process Systems® is the creator of the original Fluidizing Paddle Blender - OptimaBlend® - and two decades later it continues to offer a balance of mixing speed and efficiency with low equipment cost and consumed power.

OptimaBlend® eliminates roll apart segregation caused by gravity when mixing ingredients of greatly varying density, shape, and size by fluidizing. Mechanical fluidization is achieved by a combination of defined geometry lifting action with a triple, multi-zoned rotor turning about 80% faster than a traditional ribbon blender.

+ Design Features & Benefits

High efficiency design

- Mechanical fluidization assures homogeneous mixes independent of large range of particle size, shape, or density
- Low CV - Coefficient of Variation (measures mixture uniformity)
- Low consumed power and hp/ton

Increased production capacity

- Up to ten times the throughput versus ribbon blenders

Low shear design

- Extremely gentle with fragile ingredients
- Minimal heat generated due to internal friction

High particle movement

- Fast and even liquid addition and coating

No over- or demixing issues

Sanitary design

- Stainless steel construction
- One-piece tank weldment
- Solid bar agitator shaft
- All continuous welds
- Product contact surfaces have a #4 ground finish or better. Free of pits, cracks, folds, and weld marks

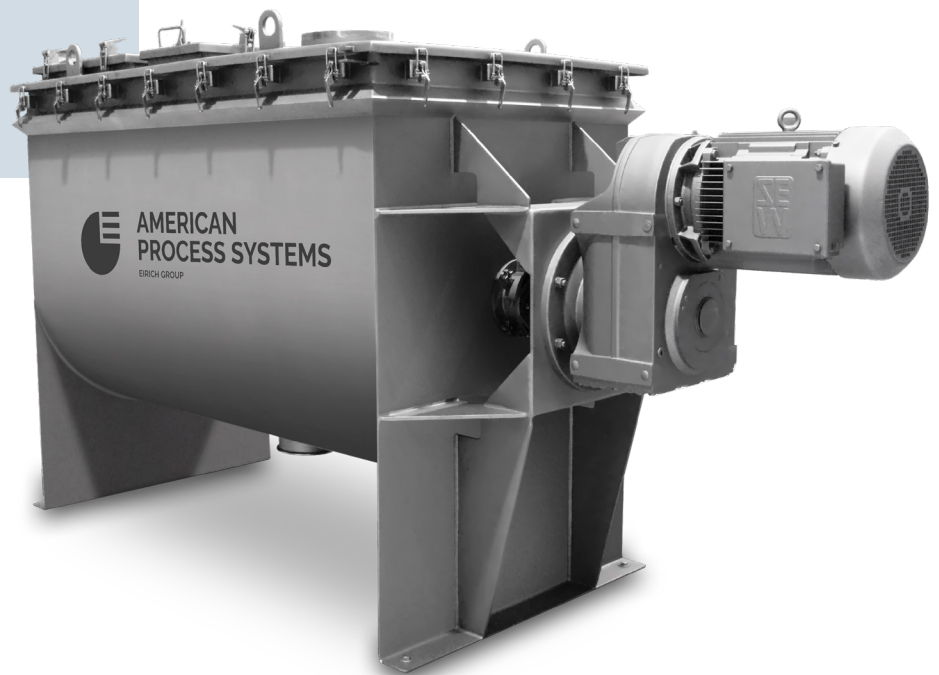



Mixing Applications

Examples of OptimaBlend® applications



- Bakery premix
- Batters and breadings
- Seasonings
- Flavorings
- Soup mix
- Trail mix
- Snacks
- Flavoring of whole coffee beans and ground coffee
- Flavored instant coffee blends
- Tea blends and flavoring
- IQF vegetables
- Infant formula
- Nutraceuticals
- Sport/Nutritional supplements
- Whey protein powders
- Pharmaceuticals
- Animal feeds

And many more



✚ Ask us about your application

Fluidizing Paddle Blender vs. Ribbon Blender

	<p>OptimaBlend® Fluidizing Paddle Blender</p>	
<p>Inner and outer paddles on the triple action, multi-zone rotor.</p>		<p>Double or triple action with blending occurring in the small voided areas right behind the blending ribbons.</p>
<p>Higher tip speed - more than twice that of comparably sized ribbon blenders - creating the optimum fluidized bed mixing environment.</p>	<p>Methodology</p>	<p>Low tip speed.</p>
<p>30-60 seconds for dry applications.</p>	<p>RPM</p>	
<p>The OptimaBlend® mixing technology provides the ideal environment for effectively mixing a wide distribution of particle size and bulk densities without segregation.</p>	<p>Mix time</p>	<p>5-6 minutes for dry applications.</p>
<p>≤0.5% standard deviation and ≤5% coefficient of variation with 0.25 lb sample.</p>	<p>Product characteristics (shape, size, density)</p>	<p>Extended mixing times are required to blend powders with various particle size and density. Potential segregation may occur in the mixer.</p>
<p>None.</p>	<p>Mix quality</p>	<p>5% standard deviation with 10% coefficient of variation is common with 0.5 lb sample.</p>
<p>The ability to mix in approx. 30-60 seconds means potentially 80% less energy consumption for any given batch.</p>	<p>Product degradation</p>	<p>Could be substantial dependent upon materials.</p>
<p>Very low or minimal.</p>	<p>Hp/Energy consumption</p>	<p>1 hp for every 100-150 lbs. Product dependent.</p>
<p>Random location.</p>	<p>Shear/Heat</p>	<p>Slight, moderate.</p>
	<p>Filling/Loading</p>	<p>As close to the center as possible.</p>

Combination of Options

- Tailored to Your Application

Engineered solutions

We take pride in our engineering and manufacturing skill sets, tailoring our mixing equipment to clients' specific process requirements.

Cover options

- Bulk bag inlet port with screen and magnetic grating
- Dust-controlled, easy to clean blender cover
- Covers for hand dumping and easy cleanability
- Removable, pneumatically vibrated tray
- Rare earth or ceramic magnetic grating
- Pneumatically actuated cover assembly
- Metal-detectable and removable A-gasket for dust control and easy cleaning

Direct drive options (dependent on blender size)

- In-line shaft mount
- Right angle shaft mount

Chopper motor options

- X-mas style chopper head for high shear
- Tulip style chopper head for medium shear

Our unique chopper motors are coupling free



Bulk bag inlet port



Vibratory tray assembly

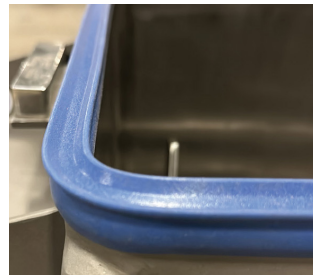

Metal-detectable A-gasket



Pneumatically actuated cover

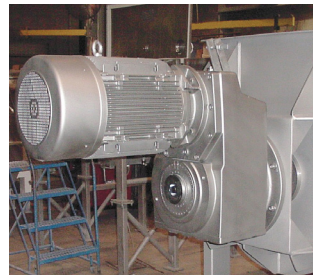

Direct drive, in-line shaft mount



Direct drive, right angle shaft mount



Tulip-style chopper head



X-mas style chopper head



USDA Dairy Standard slide gate

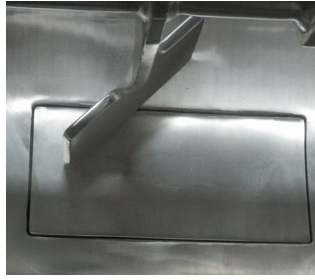

Flush bottom drop gate valve

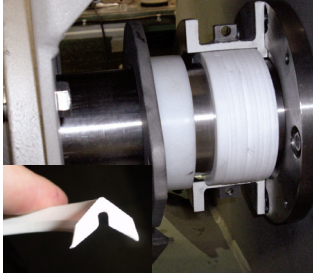

Split, removable packing gland seals with Teflon V-rings



Bag dump station

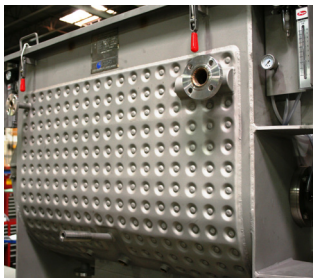

Dimpled jacket



Side access doors



Tri-clamped ferrules for liquid addition port



360° spray nozzles for CIP kit



Trapped keys



Control panels

Discharge options

- Slide/roller gate, or optional USDA Dairy approved slide gate
- Flush bottom drop gate
- Bombay doors

Seal options

- Seal saver kit. Includes filter regulator and flow meter
- Split, removable packing gland seals with Teflon V-rings. Suitable for USDA dairy applications

Other options

- Bag dump station, filtered or non filtered
- Dimpled jacket for heating/cooling
- Side access doors
- Compressed air header for use with seals and discharge valve
- CO₂/N₂ injection nozzles
- Tri-clamped liquid addition port
- Clean-in-place kit with 360° rotating spray nozzles
- Trapped keys
- Shrouded endplates for a more sanitary design
- Control panels

Dimensions & Drawings

+ Ask us which blender size best fits your application

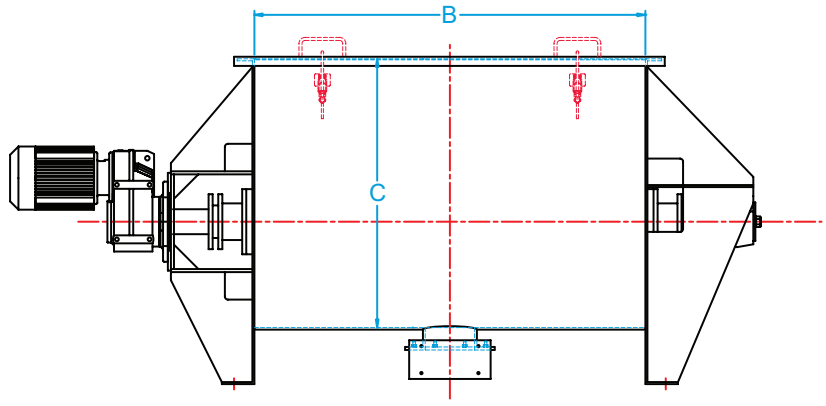
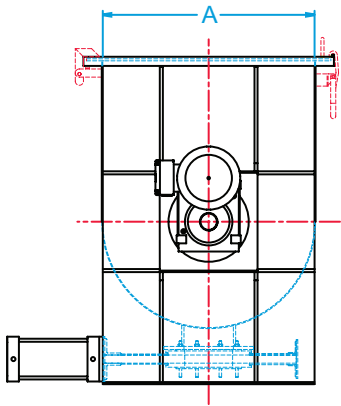

Model	Capacity (ft ³) Working Volume	HP* *Depending on Application	Dimensions (inches)		
			A	B	C
FPB-1P5	1.5	3	14	24	21
FPB-005	5	7.5 / 10	21	36	28
FPB-010	10	10 / 20	26	48	33
FPB-020	20	20 / 30	32	54	39
FPB-030	30	25 / 40	37	66	44
FPB-050	50	40 / 60	45	78	52
FPB-075	75	50 / 100	50	90	57
FPB-100	100	60 / 125	54	96	61
FPB-125	125	75 / 125	60	108	67
FPB-150	150	100 / 150	66	108	73
FPB-200	200	125 / 200	72	120	79
FPB-300	300	125 / 200	80	144	87
FPB-400	400	150 / 200	88	156	93

APS Ancillary Equipment

Modular Bag Dump Stations For existing or new setups

Bag dump stations by American Process Systems® are modular in design and easily adaptable to fit into virtually any existing or future setup. This intelligently engineered dust collection system provides dependable dust control by immediately drawing dust away from the operator. The result is a clean, healthy work environment.



Scan the QR code for more detailed information on bag dump stations

Product Conditioners De-agglomeration technology

Our Product Conditioner provides a cost-effective solution for bagged materials that have been solidified, hardened, or agglomerated, and that often cause bottlenecks in the manufacturing process.

The Product Conditioner utilizes a U-shaped screen frame and a fully welded triple-bar shaft that safely and efficiently returns solid materials to a free-flowing state. The perforated and removable screen assembly allows for a quick changeover to a different screen configuration for each application. Two double-hinged side doors provide easy access for cleaning. The Product Conditioner can be used as a stand-alone unit or be placed on top of a blender.

Technology & design benefits

- Efficient dust removal
- Controlled dust exposure
- Minimal loss of product
- Effortless system integration
- Clean and healthy work environment
- Simplified product charging

Filtered station

- Efficient filtration
- In-line filter cleaning via alternating blasts of air
- Easy, tool-free filter replacement
- Light-weight, highly efficient wide-pleated filter cartridges

Non-filtered station

- Attaches to customer's centralized dust collection system
- Has no filters or blower system

Installation

- On top of blender, welded or flanged
- Free-standing unit
- On top of APS Product Conditioner



Scan the QR code for more detailed information on product conditioners



APS Control Panels

Why buy your controls from Eirich Machines? Three words: Quality - Safety - Performance

Quality

At Eirich Machines we build our own control panels. We are a UL 508a listed panel shop and are ISO 9001:2015 certified. We carefully choose the components we use to design our machine controls, selecting them based on performance, reliability, and price. All machine controls are fully tested with their respective equipment in a rigorous QC process.

Safety

Today there is an ever-changing emphasis on machine safety and the world moving towards a global standard for machine safety. At Eirich Machines we take machine safety very seriously. We work hard to keep informed on the latest safety standards and design our control systems with this in mind. We implement the latest safety technology that meets today's standard and in to the future.

Functional safety standards:

IEC62061 + ISO 13849-1 => IEC/ISO 17305 (2016/18)

Performance

You invest a lot of capital in high-performance mixing and blending equipment. Why would you not want the control of that equipment to perform to the same standard? At Eirich Machines we know our equipment better than anyone. We design our control system to be precisely matched to our machines. Designed to the latest standards with the latest technology, you can trust that our equipment will be reliable and supportable long into the future.

Choose between Standard or Performance control panel

The **standard** control panel has a 3.8" color screen and setting of single timer, speed, and display of agitator kW.

The **performance** control panel has a 7" color screen with selection of modes, times, and ten different preset mix profiles. It also displays blender status, drive status, and kW.

Both types are cUL listed, made of 304 stainless steel, and have operator push buttons as required for manual operation.



APS standard control panel with
3.8-inch color screen



APS performance control panel with
7-inch color screen

Test Lab Services

Put us to the test!

We have an in-house, fully equipped test lab with blenders, mixers, dryers, and reactors. We welcome you to visit and test your product in our equipment. It is the perfect opportunity for R&D, recipe optimization, and to see our manufacturing.

If you can't visit us, we offer virtual trials via livestream video. You interact with our Test Lab Manager during the trials, watch live as your product is processed, and see microscope images of your processed product. Our detailed test reports include photos and video links.

Rent our equipment!

You can also rent our lab-size fluidizing paddle blender (FPB-1P5) and try it at your own facility. Optional ribbon agitator is available.

"I would like to commend you on the trial recording as it demonstrated the dedicated passion and expertise of your team. The team's confidence in your equipment was illustrated when you can record the trial on an unknown material". - Verne Hogg, ZMM

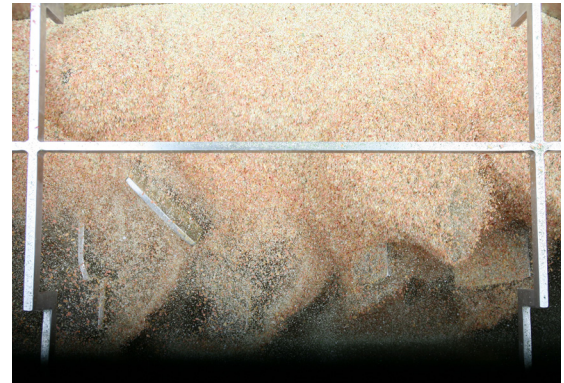

Scan the QR code to learn more about our FPB-1P5 lab blender

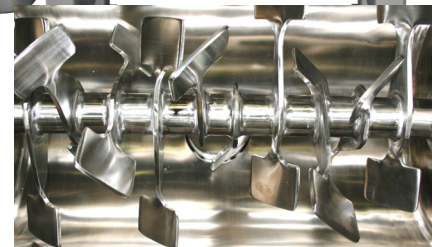
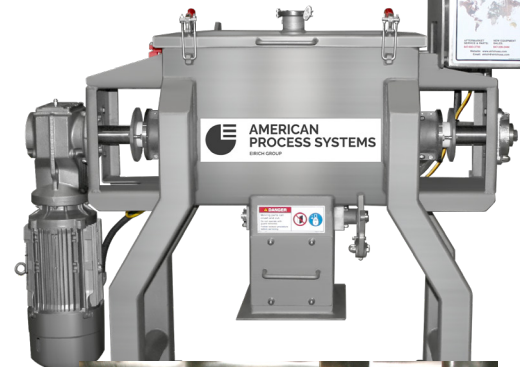

Customer Support

Our Customer Support team is here for you!

We build our blenders to last for decades, but they do need routine maintenance. Our Customer Support team is here for you when you need spare parts, equipment inspection, training, or have questions about your blender.

Want to learn more?

Send an email to customersupport@eirichusa.com or call 847-693-3700.



Scan the QR code to learn more
about our Ribbon Blenders

Version July 2024. Subject to change.



Eirich Machines, part of worldwide Eirich Group, is an international supplier of machinery, systems, and services for material processing. With the two product lines EIRICH and American Process Systems® (APS), we offer the most comprehensive range of mixers, blenders, pelletizers, dryers, and grinding mills. Eirich Machines is your one-stop shop for all material processing needs with sales, test lab, engineering, manufacturing, and customer support in one location.

Our APS product line includes:

- OptimaBlend® Fluidizing Paddle Blenders
- OptimalBlend™ Fluidizing Zone Mixers
- Ribbon Blenders
- Paddle-Ribbon Blenders
- Paddle Blenders
- Plow Blenders
- Dryers/Reactors
- Filtered and Non-Filtered Bag Dump Stations
- Product Conditioners for De-Lumping

Eirich Machines, Inc.

4033 Ryan Road
Gurnee, IL 60031
847-336-2444
eirich@eirichusa.com

For more information visit us at:

www.eirichusa.com